

# MODBUS CONNECTION C5

C5 controller supports Modbus RTU and Modbus TCP/IP protocols

**Modbus RTU** protocol works via RS485 interface, connection is provided to terminals 1,2,3 of the C5 controller (Pic. 1). Default interface settings and ID are as follows:

Baudrate	19200
Word length	8
Parity	EVEN
Stop bits	1
Modbus ID	1

These settings can be changed using laptop connected to webserver (Pic. 2). To connect devices use twisted pair cable. Maximum cable length is 150m. Connect GND cables together, if distance between the RS485 interfaces is more than 10m.

**Modbus TCP** protocol uses Ethernet interface, connection is provided to RJ-45 socket (Pic.1) on the C5 controller (CAT5 cable is recommended). The maximum cable length between device and C5 controller board must not exceed 100m. Default IP address is 192.168.0.50, port 502. The IP address can be changed using laptop connected to webserver (Pic. 2) or control panel (Pic. 3).

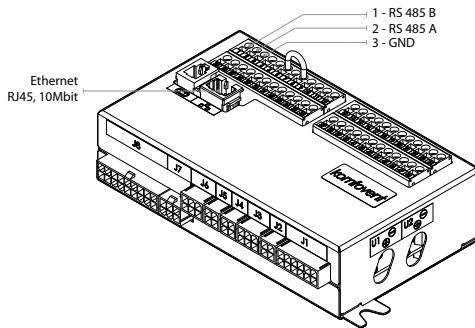

Picture 1. C5 controller board

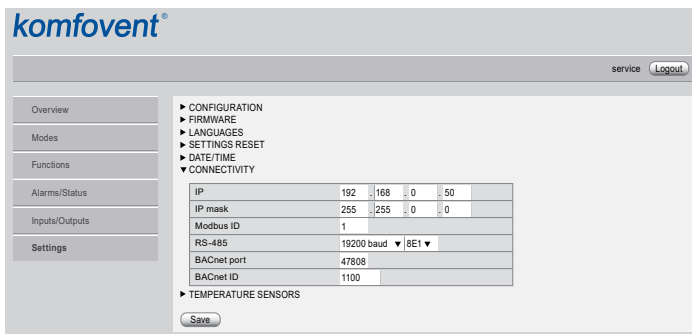

Picture 2. Connectivity settings



When using Modbus RTU or Modbus TCP/IP, minimum polling time should be 500 ms or longer. In cases when multiple AHU's are connected to the same Modbus network, at least 1s. polling time is recommended.

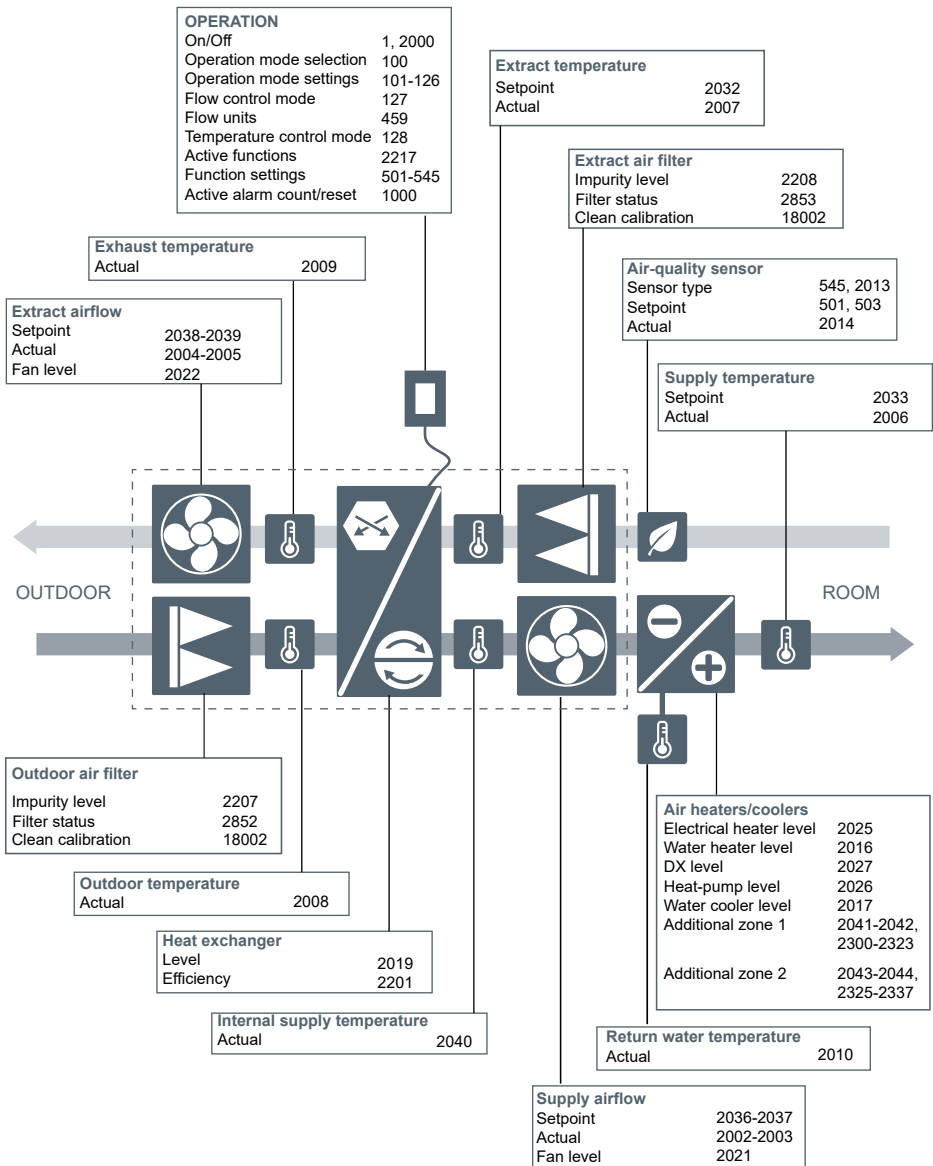

Following tables lists available Modbus registers

MODES						
Modbus register	Data				Description	Data values
	Type	Access	Range	Default		
1	int	R/W	0-1	0	AHU On/Off control	0-Off, 1-On
100	int	R/W	1-6	1	Operation mode selection	1-Comfort1, 2-Comfort2, 3-Economy1, 4-Economy2, 5-Special, 6-Program
101-102	int32	R/W	-	-	Comfort1: Supply flow	Auto-correction to be within allowed range (20-100% of maximum supply flow or 0)
103-104	int32	R/W	-	-	Comfort1: Extract flow	Auto-correction to be within allowed range (20-100% of maximum extract flow or 0)
105	int	R/W	50-400	210	Comfort1: Setpoint temperature	200 => 20,0C
106-107	int32	R/W	-	-	Comfort2: Supply flow	Auto-correction to be within allowed range (20-100% of maximum supply flow or 0)
108-109	int32	R/W	-	-	Comfort2: Extract flow	Auto-correction to be within allowed range (20-100% of maximum extract flow or 0)
110	int	R/W	50-400	210	Comfort2: Setpoint temperature	200 => 20,0C
111-112	int32	R/W	-	-	Economy1: Supply flow	Auto-correction to be within allowed range (20-100% of maximum supply flow or 0)
113-114	int32	R/W	-	-	Economy1: Extract flow	Auto-correction to be within allowed range (20-100% of maximum extract flow or 0)
115	int	R/W	50-400	200	Economy1: Setpoint temperature	200 => 20,0C
116-117	int32	R/W	-	-	Economy2: Supply flow	Auto-correction to be within allowed range (20-100% of maximum supply flow or 0)
118-119	int32	R/W	-	-	Economy2: Extract flow	Auto-correction to be within allowed range (20-100% of maximum extract flow or 0)
120	int	R/W	50-400	190	Economy2: Setpoint temperature	200 => 20,0C
121-122	int32	R/W	-	-	Special: Supply flow	Auto-correction to be within allowed range (20-100% of maximum supply flow or 0)
123-124	int32	R/W	-	-	Special: Extract flow	Auto-correction to be within allowed range (20-100% of maximum extract flow or 0)
125	int	R/W	50-400	210	Special: Setpoint temperature	200 => 20,0C
126	bin	R/W	-	31	Special: Configuration	b4-Dehumidifying, b3-Humidifying, b2-Recirculation, b1-Cooling, b0-Heating (1-Enable, 0-Disable)
127	int	R/W	0-2	0	Flow control mode	0-CAV, 1-VAV, 2 - DCV
128	int	R/W	0-2	0	Temp. control mode	0-Supply, 1-Extract, 2-Room

129	int	R/W	0-4	0	VAV status/ calibration	0-Not calibrated, 1-Calibrating, 2-Supply, 3-Extract, 4-Double. Write 0x99C5 to start VAV calibration
130	int	R/W	100-5000	500	VAV sensors range	500 => 500Pa
131	int	R/W	0-4500	0	Nominal supply pressure	Auto-correction to be within allowed range (0-90% of VAV sensors range)
132	int	R/W	0-4500	0	Nominal exhaust pressure	Auto-correction to be within allowed range (0-90% of VAV sensors range)

OPERATION PROGRAM						
Modbus register	Data				Description	Data values
	Type	Access	Range	Default		
200	bin	R/W	-	0	Event01: Days	b6-Sun, b5-Sat, b4-Fri, b3-Thu, b2-Wed, b1-Tue, b0-Mon (1-Select, 0-Deselect)
201	int8x2	R/W	0:00-23:59	0:00	Event01: Start time	0x0805 => 8:05
202	int8x2	R/W	0:00-24:00	0:00	Event01: Stop time	0x0805 => 8:05
203	int	R/W	0-5	0	Event01: Mode	0-Standby,1-Comfort1, 2-Comfort2, 3-Economy1, 4-Economy2, 5-Special
204	bin	R/W	-	0	Event02: Days	b6-Sun, b5-Sat, b4-Fri, b3-Thu, b2-Wed, b1-Tue, b0-Mon (1-Select, 0-Deselect)
205	int8x2	R/W	0:00-23:59	0:00	Event02: Start time	0x0805 => 8:05
206	int8x2	R/W	0:00-24:00	0:00	Event02: Stop time	0x0805 => 8:05
207	int	R/W	0-5	0	Event02: Mode	0-Standby,1-Comfort1, 2-Comfort2, 3-Economy1, 4-Economy2, 5-Special
208	bin	R/W	-	0	Event03: Days	b6-Sun, b5-Sat, b4-Fri, b3-Thu, b2-Wed, b1-Tue, b0-Mon (1-Select, 0-Deselect)
209	int8x2	R/W	0:00-23:59	0:00	Event03: Start time	0x0805 => 8:05
210	int8x2	R/W	0:00-24:00	0:00	Event03: Stop time	0x0805 => 8:05
211	int	R/W	0-5	0	Event03: Mode	0-Standby,1-Comfort1, 2-Comfort2, 3-Economy1, 4-Economy2, 5-Special
212	bin	R/W	-	0	Event04: Days	b6-Sun, b5-Sat, b4-Fri, b3-Thu, b2-Wed, b1-Tue, b0-Mon (1-Select, 0-Deselect)
213	int8x2	R/W	0:00-23:59	0:00	Event04: Start time	0x0805 => 8:05
214	int8x2	R/W	0:00-24:00	0:00	Event04: Stop time	0x0805 => 8:05
215	int	R/W	0-5	0	Event04: Mode	0-Standby,1-Comfort1, 2-Comfort2, 3-Economy1, 4-Economy2, 5-Special
216	bin	R/W	-	0	Event05: Days	b6-Sun, b5-Sat, b4-Fri, b3-Thu, b2-Wed, b1-Tue, b0-Mon (1-Select, 0-Deselect)
217	int8x2	R/W	0:00-23:59	0:00	Event05: Start time	0x0805 => 8:05
218	int8x2	R/W	0:00-24:00	0:00	Event05: Stop time	0x0805 => 8:05

OPERATION PROGRAM						
Modbus register	Data				Description	Data values
	Type	Access	Range	Default		
219	int	R/W	0-5	0	Event05: Mode	0-Standby,1-Comfort1, 2-Comfort2, 3-Economy1, 4-Economy2, 5-Special
220	bin	R/W	-	0	Event06: Days	b6-Sun, b5-Sat, b4-Fri, b3-Thu, b2-Wed, b1-Tue, b0-Mon (1-Select, 0-Deselect)
221	int8x2	R/W	0:00-23:59	0:00	Event06: Start time	0x0805 => 8:05
222	int8x2	R/W	0:00-24:00	0:00	Event06: Stop time	0x0805 => 8:05
223	int	R/W	0-5	0	Event06: Mode	0-Standby,1-Comfort1, 2-Comfort2, 3-Economy1, 4-Economy2, 5-Special
224	bin	R/W	-	0	Event07: Days	b6-Sun, b5-Sat, b4-Fri, b3-Thu, b2-Wed, b1-Tue, b0-Mon (1-Select, 0-Deselect)
225	int8x2	R/W	0:00-23:59	0:00	Event07: Start time	0x0805 => 8:05
226	int8x2	R/W	0:00-24:00	0:00	Event07: Stop time	0x0805 => 8:05
227	int	R/W	0-5	0	Event07: Mode	0-Standby,1-Comfort1, 2-Comfort2, 3-Economy1, 4-Economy2, 5-Special
228	bin	R/W	-	0	Event08: Days	b6-Sun, b5-Sat, b4-Fri, b3-Thu, b2-Wed, b1-Tue, b0-Mon (1-Select, 0-Deselect)
229	int8x2	R/W	0:00-23:59	0:00	Event08: Start time	0x0805 => 8:05
230	int8x2	R/W	0:00-24:00	0:00	Event08: Stop time	0x0805 => 8:05
231	int	R/W	0-5	0	Event08: Mode	0-Standby,1-Comfort1, 2-Comfort2, 3-Economy1, 4-Economy2, 5-Special
232	bin	R/W	-	0	Event09: Days	b6-Sun, b5-Sat, b4-Fri, b3-Thu, b2-Wed, b1-Tue, b0-Mon (1-Select, 0-Deselect)
233	int8x2	R/W	0:00-23:59	0:00	Event09: Start time	0x0805 => 8:05
234	int8x2	R/W	0:00-24:00	0:00	Event09: Stop time	0x0805 => 8:05
235	int	R/W	0-5	0	Event09: Mode	0-Standby,1-Comfort1, 2-Comfort2, 3-Economy1, 4-Economy2, 5-Special
236	bin	R/W	-	0	Event10: Days	b6-Sun, b5-Sat, b4-Fri, b3-Thu, b2-Wed, b1-Tue, b0-Mon (1-Select, 0-Deselect)
237	int8x2	R/W	0:00-23:59	0:00	Event10: Start time	0x0805 => 8:05
238	int8x2	R/W	0:00-24:00	0:00	Event10: Stop time	0x0805 => 8:05
239	int	R/W	0-5	0	Event10: Mode	0-Standby,1-Comfort1, 2-Comfort2, 3-Economy1, 4-Economy2, 5-Special
240	bin	R/W	-	0	Event11: Days	b6-Sun, b5-Sat, b4-Fri, b3-Thu, b2-Wed, b1-Tue, b0-Mon (1-Select, 0-Deselect)
241	int8x2	R/W	0:00-23:59	0:00	Event11: Start time	0x0805 => 8:05

OPERATION PROGRAM						
Modbus register	Data				Description	Data values
	Type	Access	Range	Default		
242	int8x2	R/W	0:00-24:00	0:00	Event11: Stop time	0x0805 => 8:05
243	int	R/W	0-5	0	Event11: Mode	0-Standby,1-Comfort1, 2-Comfort2, 3-Economy1, 4-Economy2, 5-Special
244	bin	R/W	-	0	Event12: Days	b6-Sun, b5-Sat, b4-Fri, b3-Thu, b2-Wed, b1-Tue, b0-Mon (1-Select, 0-Deselect)
245	int8x2	R/W	0:00-23:59	0:00	Event12: Start time	0x0805 => 8:05
246	int8x2	R/W	0:00-24:00	0:00	Event12: Stop time	0x0805 => 8:05
247	int	R/W	0-5	0	Event12: Mode	0-Standby,1-Comfort1, 2-Comfort2, 3-Economy1, 4-Economy2, 5-Special
248	bin	R/W	-	0	Event13: Days	b6-Sun, b5-Sat, b4-Fri, b3-Thu, b2-Wed, b1-Tue, b0-Mon (1-Select, 0-Deselect)
249	int8x2	R/W	0:00-23:59	0:00	Event13: Start time	0x0805 => 8:05
250	int8x2	R/W	0:00-24:00	0:00	Event13: Stop time	0x0805 => 8:05
251	int	R/W	0-5	0	Event13: Mode	0-Standby,1-Comfort1, 2-Comfort2, 3-Economy1, 4-Economy2, 5-Special
252	bin	R/W	-	0	Event14: Days	b6-Sun, b5-Sat, b4-Fri, b3-Thu, b2-Wed, b1-Tue, b0-Mon (1-Select, 0-Deselect)
253	int8x2	R/W	0:00-23:59	0:00	Event14: Start time	0x0805 => 8:05
254	int8x2	R/W	0:00-24:00	0:00	Event14: Stop time	0x0805 => 8:05
255	int	R/W	0-5	0	Event14: Mode	0-Standby,1-Comfort1, 2-Comfort2, 3-Economy1, 4-Economy2, 5-Special
256	bin	R/W	-	0	Event15: Days	b6-Sun, b5-Sat, b4-Fri, b3-Thu, b2-Wed, b1-Tue, b0-Mon (1-Select, 0-Deselect)
257	int8x2	R/W	0:00-23:59	0:00	Event15: Start time	0x0805 => 8:05
258	int8x2	R/W	0:00-24:00	0:00	Event15: Stop time	0x0805 => 8:05
259	int	R/W	0-5	0	Event15: Mode	0-Standby,1-Comfort1, 2-Comfort2, 3-Economy1, 4-Economy2, 5-Special
260	bin	R/W	-	0	Event16: Days	b6-Sun, b5-Sat, b4-Fri, b3-Thu, b2-Wed, b1-Tue, b0-Mon (1-Select, 0-Deselect)
261	int8x2	R/W	0:00-23:59	0:00	Event16: Start time	0x0805 => 8:05
262	int8x2	R/W	0:00-24:00	0:00	Event16: Stop time	0x0805 => 8:05
263	int	R/W	0-5	0	Event16: Mode	0-Standby,1-Comfort1, 2-Comfort2, 3-Economy1, 4-Economy2, 5-Special
264	bin	R/W	-	0	Event17: Days	b6-Sun, b5-Sat, b4-Fri, b3-Thu, b2-Wed, b1-Tue, b0-Mon (1-Select, 0-Deselect)

OPERATION PROGRAM						
Modbus register	Data				Description	Data values
	Type	Access	Range	Default		
265	int8x2	R/W	0:00-23:59	0:00	Event17: Start time	0x0805 => 8:05
266	int8x2	R/W	0:00-24:00	0:00	Event17: Stop time	0x0805 => 8:05
267	int	R/W	0-5	0	Event17: Mode	0-Standby,1-Comfort1, 2-Comfort2, 3-Economy1, 4-Economy2, 5-Special
268	bin	R/W	-	0	Event18: Days	b6-Sun, b5-Sat, b4-Fri, b3-Thu, b2-Wed, b1-Tue, b0-Mon (1-Select, 0-Deselect)
269	int8x2	R/W	0:00-23:59	0:00	Event18: Start time	0x0805 => 8:05
270	int8x2	R/W	0:00-24:00	0:00	Event18: Stop time	0x0805 => 8:05
271	int	R/W	0-5	0	Event18: Mode	0-Standby,1-Comfort1, 2-Comfort2, 3-Economy1, 4-Economy2, 5-Special
272	bin	R/W	-	0	Event19: Days	b6-Sun, b5-Sat, b4-Fri, b3-Thu, b2-Wed, b1-Tue, b0-Mon (1-Select, 0-Deselect)
273	int8x2	R/W	0:00-23:59	0:00	Event19: Start time	0x0805 => 8:05
274	int8x2	R/W	0:00-24:00	0:00	Event19: Stop time	0x0805 => 8:05
275	int	R/W	0-5	0	Event19: Mode	0-Standby,1-Comfort1, 2-Comfort2, 3-Economy1, 4-Economy2, 5-Special
276	bin	R/W	-	0	Event20: Days	b6-Sun, b5-Sat, b4-Fri, b3-Thu, b2-Wed, b1-Tue, b0-Mon (1-Select, 0-Deselect)
277	int8x2	R/W	0:00-23:59	0:00	Event20: Start time	0x0805 => 8:05
278	int8x2	R/W	0:00-24:00	0:00	Event20: Stop time	0x0805 => 8:05
279	int	R/W	0-5	0	Event20: Mode	0-Standby,1-Comfort1, 2-Comfort2, 3-Economy1, 4-Economy2, 5-Special

HOLLYDAY SCHEDULE						
Modbus register	Data				Description	Data values
	Type	Access	Range	Default		
300	int	R/W	2010-2250		Event01: Start year	
301	int8x2	R/W	01.01-12.31		Event01: Start date	0x020C => Feb12
302	int	R/W	2010-2250		Event01: Stop year	
303	int8x2	R/W	01.01-12.31		Event01: Stop date	0x020C => Feb12
304	int	R/W	0-6		Event01: Mode	0-Standby, 1-Comfort1, 2-Comfort2, 3-Economy1, 4-Economy2, 5-Special, 6-Program
305	int	R/W	2010-2250		Event02: Start year	

HOLLYDAY SCHEDULE						
Modbus register	Data				Description	Data values
	Type	Access	Range	Default		
306	int8x2	R/W	01.01-12.31		Event02: Start date	0x020C => Feb12
307	int	R/W	2010-2250		Event02: Stop year	
308	int8x2	R/W	01.01-12.31		Event02: Stop date	0x020C => Feb12
309	int	R/W	0-6		Event02: Mode	0-Standby, 1-Comfort1, 2-Comfort2, 3-Economy1, 4-Economy2, 5-Special, 6-Program
310	int	R/W	2010-2250		Event03: Start year	
311	int8x2	R/W	01.01-12.31		Event03: Start date	0x020C => Feb12
312	int	R/W	2010-2250		Event03: Stop year	
313	int8x2	R/W	01.01-12.31		Event03: Stop date	0x020C => Feb12
314	int	R/W	0-6		Event03: Mode	0-Standby, 1-Comfort1, 2-Comfort2, 3-Economy1, 4-Economy2, 5-Special, 6-Program
315	int	R/W	2010-2250		Event04: Start year	
316	int8x2	R/W	01.01-12.31		Event04: Start date	0x020C => Feb12
317	int	R/W	2010-2250		Event04: Stop year	
318	int8x2	R/W	01.01-12.31		Event04: Stop date	0x020C => Feb12
319	int	R/W	0-6		Event04: Mode	0-Standby, 1-Comfort1, 2-Comfort2, 3-Economy1, 4-Economy2, 5-Special, 6-Program
320	int	R/W	2010-2250		Event05: Start year	
321	int8x2	R/W	01.01-12.31		Event05: Start date	0x020C => Feb12
322	int	R/W	2010-2250		Event05: Stop year	
323	int8x2	R/W	01.01-12.31		Event05: Stop date	0x020C => Feb12
324	int	R/W	0-6		Event05: Mode	0-Standby, 1-Comfort1, 2-Comfort2, 3-Economy1, 4-Economy2, 5-Special, 6-Program
325	int	R/W	2010-2250		Event06: Start year	
326	int8x2	R/W	01.01-12.31		Event06: Start date	0x020C => Feb12
327	int	R/W	2010-2250		Event06: Stop year	

HOLLYDAY SCHEDULE						
Modbus register	Data				Description	Data values
	Type	Access	Range	Default		
328	int8x2	R/W	01.01-12.31		Event06: Stop date	0x020C => Feb12
329	int	R/W	0-6		Event06: Mode	0-Standby, 1-Comfort1, 2-Comfort2, 3-Economy1, 4-Economy2, 5-Special, 6-Program
330	int	R/W	2010-2250		Event07: Start year	
331	int8x2	R/W	01.01-12.31		Event07: Start date	0x020C => Feb12
332	int	R/W	2010-2250		Event07: Stop year	
333	int8x2	R/W	01.01-12.31		Event07: Stop date	0x020C => Feb12
334	int	R/W	0-6		Event07: Mode	0-Standby, 1-Comfort1, 2-Comfort2, 3-Economy1, 4-Economy2, 5-Special, 6-Program
335	int	R/W	2010-2250		Event08: Start year	
336	int8x2	R/W	01.01-12.31		Event08: Start date	0x020C => Feb12
337	int	R/W	2010-2250		Event08: Stop year	
338	int8x2	R/W	01.01-12.31		Event08: Stop date	0x020C => Feb12
339	int	R/W	0-6		Event08: Mode	0-Standby, 1-Comfort1, 2-Comfort2, 3-Economy1, 4-Economy2, 5-Special, 6-Program
340	int	R/W	2010-2250		Event09: Start year	
341	int8x2	R/W	01.01-12.31		Event09: Start date	0x020C => Feb12
342	int	R/W	2010-2250		Event09: Stop year	
343	int8x2	R/W	01.01-12.31		Event09: Stop date	0x020C => Feb12
344	int	R/W	0-6		Event09: Mode	0-Standby, 1-Comfort1, 2-Comfort2, 3-Economy1, 4-Economy2, 5-Special, 6-Program
345	int	R/W	2010-2250		Event10: Start year	
346	int8x2	R/W	01.01-12.31		Event10: Start date	0x020C => Feb12
347	int	R/W	2010-2250		Event10: Stop year	
348	int8x2	R/W	01.01-12.31		Event10: Stop date	0x020C => Feb12

HOLLYDAY SCHEDULE						
Modbus register	Data				Description	Data values
	Type	Access	Range	Default		
349	int	R/W	0-6		Event10: Mode	0-Standby, 1-Comfort1, 2-Comfort2, 3-Economy1, 4-Economy2, 5-Special, 6-Program

RECIRCULATION SCHEDULE						
Modbus register	Data				Description	Data values
	Type	Access	Range	Default		
400	bin	R/W	-	0	Event01: Days	b6-Sun, b5-Sat, b4-Fri, b3-Thu, b2-Wed, b1-Tue, b0-Mon (1-Select, 0-Deselect)
401	int8x2	R/W	0:00-23:59	0:00	Event01: Start time	0x0805 => 8:05
402	int8x2	R/W	0:00-24:00	0:00	Event01: Stop time	0x0805 => 8:05
403	int	R/W	0..100	0	Event01: Level	
404	bin	R/W	-	0	Event02: Days	b6-Sun, b5-Sat, b4-Fri, b3-Thu, b2-Wed, b1-Tue, b0-Mon (1-Select, 0-Deselect)
405	int8x2	R/W	0:00-23:59	0:00	Event02: Start time	0x0805 => 8:05
406	int8x2	R/W	0:00-24:00	0:00	Event02: Stop time	0x0805 => 8:05
407	int	R/W	0..100	0	Event02: Level	
408	bin	R/W	-	0	Event03: Days	b6-Sun, b5-Sat, b4-Fri, b3-Thu, b2-Wed, b1-Tue, b0-Mon (1-Select, 0-Deselect)
409	int8x2	R/W	0:00-23:59	0:00	Event03: Start time	0x0805 => 8:05
410	int8x2	R/W	0:00-24:00	0:00	Event03: Stop time	0x0805 => 8:05
411	int	R/W	0..100	0	Event03: Level	
412	bin	R/W	-	0	Event04: Days	b6-Sun, b5-Sat, b4-Fri, b3-Thu, b2-Wed, b1-Tue, b0-Mon (1-Select, 0-Deselect)
413	int8x2	R/W	0:00-23:59	0:00	Event04: Start time	0x0805 => 8:05
414	int8x2	R/W	0:00-24:00	0:00	Event04: Stop time	0x0805 => 8:05
415	int	R/W	0..100	0	Event04: Level	
416	bin	R/W	-	0	Event05: Days	b6-Sun, b5-Sat, b4-Fri, b3-Thu, b2-Wed, b1-Tue, b0-Mon (1-Select, 0-Deselect)
417	int8x2	R/W	0:00-23:59	0:00	Event05: Start time	0x0805 => 8:05
418	int8x2	R/W	0:00-24:00	0:00	Event05: Stop time	0x0805 => 8:05
419	int	R/W	0..100	0	Event05: Level	

SETTINGS						
Modbus register	Data				Description	Data values
	Type	Access	Range	Default		
450	int8x2	R/W	0:00-23:59	0:00	Time	0x0805 => 8:05
451	int	R/W	0-59	0	Seconds	
452	int	R	1-7	7	Day of week	1-Mon, 2-Tue, 3-Wed, 4-Thu, 5-Fri, 6-Sat, 7-Sun
453	int8x2	R/W	01.01-12.31	01.01	Date	0x020C => Feb12
454	int	R/W	2010-2250	2012	Year	
455	int	R/W	0-3	0	Language	0-English,1-Lithuanian,2-Russian, 3-Polish
456	int	R/W	1-247	1	Modbus address	
457-458	int32	R/W		192.168.0.50	IP address	
459	int	R/W	0-3	0	Flow units	0-m3/h, 1-l/s, 2-m3/s, 3-Pa
460-467	int8x2	R	-		AHU S/N	
468-479	int8x2	R			AHU name	
480-481	int8x2	R/W			IP mask	With auto correction
482	int	R/W	-	19200 8E1	RS-485	Speed (b4..b3): 0 – 9600, 1 – 19200, 2 – 38400, 3 – 57600; parity (b1): 0 – none, 1 – even; stop bits (b0): 0 – 1, 1 – 2
483	char	R/W	0..1	0	Daylight saving time	0-Disable, 1-Enable
485	short	R/W	0..65535	47809	BACnet port	
486-487	int32	R/W	0..4194303	20087	BACnet ID	

FUNCTIONS						
Modbus register	Data				Description	Data values
	Type	Access	Range	Default		
501	int	R/W	200..1800	1000	Air quality control: Setpoint 1	200..1800ppm, 10..90%, 10..90%RH, 5..45C
502	int	R/W	1..5	1	Air quality control: Mode 1	1-Comfort1, 2-Comfort2, 3-Economy1, 4-Economy2, 5-Special
503	int	R/W	200..1800	1000	Air quality control: Setpoint 2	200..1800ppm, 10..90%, 10..90%RH, 5..45C
504	int	R/W	1..5	1	Air quality control: Mode 1	1-Comfort1, 2-Comfort2, 3-Economy1, 4-Economy2, 5-Special
505	int	R/W	0..1	0	Outdoor comp. ventilation: Enable/Disable	0-Disable, 1-Enable

FUNCTIONS						
Modbus register	Data				Description	Data values
	Type	Access	Range	Default		
506	int	R/W	-400..500	-400	Outdoor comp. ventilation: Winter comp. stop	-150 => -15.0C
507	int	R/W	-400..500	0	Outdoor comp. ventilation: Winter comp. start	-150 => -15.0C
508	int	R/W	-400..500	200	Outdoor comp. ventilation: Summer comp. start	250 => 25.0C
509	int	R/W	-400..500	500	Outdoor comp. ventilation: Summer comp. stop	250 => 25.0C
510	int	R/W	0..1	0	Min. temperature control: Enable/Disable	0-Disable, 1-Enable
511	int	R/W	-400..500	150	Min. temperature control: Setpoint	-150 => -15.0C
512	int	R/W	0..1	1	Override function: Enable/Disable	0-Disable, 1-Enable
513	int	R/W	0..2	0	Override function: Override type	0-All time, 1-If on, 2-If off
514	int	R/W	0..6	2	Override function: Mode	0-Standby, 1-Comfort1, 2-Comfort2, 3-Economy1, 4-Economy2, 5-Special, 6-Program
515	int	R/W	0..1	0	Summer night cooling: Enable/Disable	0-Disable, 1-Enable
516	int	R/W	100..500	250	Summer night cooling: Start temperature	250 => 25.0C
517	int	R/W	0..1	0	Operation on demand: Enable/Disable	0-Disable, 1-Enable
518	int	R/W	200..1800	150	Operation on demand: Setpoint	200..1800ppm, 10..90%, 10..90%RH, 5..45C
519	int	R/W	0..1	0	Recirculation control: Enable/Disable	0-Disable, 1-Enable
520	int	R/W	200..1800	600	Recirculation control: Setpoint	200..1800ppm, 10..90%, 10..90%RH, 5..45C

FUNCTIONS						
Modbus register	Data				Description	Data values
	Type	Access	Range	Default		
521	int	R/W	0..80	30	Recirculation control: Min. fresh air	
522	int	R/W	-400..500	-400	Recirculation control: Winter recirculation end	-150 => -15.0C
523	int	R/W	-400..500	0	Recirculation control: Winter recirculation start	-150 => -15.0C
524	int	R/W	-400..500	200	Recirculation control: Summer recirculation start	250 => 25.0C
525	int	R/W	-400..500	500	Recirculation control: Summer recirculation end	250 => 25.0C
526	int	R/W	0..100	0	Recirculation control: Default recirculation	
527	int	R/W	0..100	60	Recirculation control: Activated recirculation	
528	int	R/W	0..1	0	Humidity control: Enable/Disable	0-Disable, 1-Enable
529	int	R/W	10..90	1000	Humidity control: Setpoint 1	10..90%RH
530	int	R/W	1..5	1	Humidity control: Mode 1	1-Comfort1, 2-Comfort2, 3-Economy1, 4-Economy2, 5-Special
531	int	R/W	10..90	1000	Humidity control: Setpoint 2	10..90%RH
532	int	R/W	1..5	2	Humidity control: Mode 2	1-Comfort1, 2-Comfort2, 3-Economy1, 4-Economy2, 5-Special
533	int	R/W	1..5	1	Recirculation control: Mode 1	1-Comfort1, 2-Comfort2, 3-Economy1, 4-Economy2, 5-Special
534	int	R/W	200..1800	900	Recirculation control: Setpoint 2	200..1800ppm, 10..90%, 10..90%RH, 5..45C
535	int	R/W	1..5	2	Recirculation control: Mode 2	1-Comfort1, 2-Comfort2, 3-Economy1, 4-Economy2, 5-Special
536	int	R/W	0..100	20	Recirculation control: Min. fresh air 2	
537	int	R/W	150..500	200	Summer night cooling: Stop temperature	200 => 20.0C

FUNCTIONS						
Modbus register	Data				Description	Data values
	Type	Access	Range	Default		
538	bin	R/W	0..1	0	Inspection lighting: Enable/Disable	
539	bin	R/W	0..1	0	Additional zone 1: Enable/Disable	
540	int	R/W	-400..400	210	Additional zone 1: Setpoint	200 => 20,0C
541	bin	R/W	0..1	0	Additional zone 2: Enable/Disable	
542	int	R/W	-400..400	210	Additional zone 2: Setpoint	200 => 20,0C
543	int	R/W	-500..1200	-32768	External room temperature sensor	200 => 20.0C. Overrides extract flow temperature sensor for temperature control only when written value is in range
544	int	R/W	-1..2	0	Digital input IN4 override	Overrides digital input IN4 for combined heating & cooling coil control. (-1 – function not available or disabled, 0 – heating (winter mode), 1 – cooling (summer mode), 2 – error)
545	int	R/W	0..4	0	Air quality sensor type	0 – CO2, 1 – VOCq, 2 – VOCp, 3 – RH, 4 – temperature
546	int	R/W	0..2	-	CF heat exchanger calibration	0-No calibration, 1- Calibrated, 2-Calibrating. Write 1 to start calibration
547	int	R/W	0..2	-	HUM mode	0-Supply, 1-Indoor+Supply, 2-Indoor
548	int	R/W	0..1	0	Humidity control: Type	0 - Relative humidity, 1 - Absolute humidity
549	int	R/W	0..1	0	Humidity control: Units	Relative humidity: 0 - %RH. Absolute humidity: 0 - g/m³, 1 - g/kg.
550	int	R/W	20..100	0	OCV Minimum airflow	%

ALARMS						
Modbus register	Data				Description	Data values
	Type	Access	Range	Default		
1000	int	R/W	0..10	-	Active alarms count	Writing 0x99C5 - Active alarms reset and restore previous mode
1001	hex	R		-	Active alarm 1 code (newest)	
1002	hex	R		-	Active alarm 2 code	
1003	hex	R		-	Active alarm 3 code	
1004	hex	R		-	Active alarm 4 code	
1005	hex	R		-	Active alarm 5 code	
1006	hex	R		-	Active alarm 6 code	
1007	hex	R		-	Active alarm 7 code	
1008	hex	R		-	Active alarm 8 code	
1009	hex	R		-	Active alarm 9 code	
1010	hex	R		-	Active alarm 10 code	
1100	int	R	0..50	-	Alarm history count	
1101	int	R	2010..2250	-	Alarm1(newest) year	
1102	int8x2	R	01.01-12.31	-	Alarm1(newest) month-day	0x020C => Feb12
1103	int8x2	R	0:00-23:59	-	Alarm1(newest) time	0x0805 => 8:05
1104	int	R	0..59	-	Alarm1(newest) seconds	
1105	hex	R		-	Alarm1(newest) code	4B => 0x0104
.....	.....	.....	.....	.....	.....	.....
1346	int	R	2010..2250	-	Alarm50 year	
1347	int8x2	R	01.01-12.31	-	Alarm50 month-day	0x020C => Feb12
1348	int8x2	R	0:00-23:59	-	Alarm50 time	0x0805 => 8:05
1349	int	R	0..59	-	Alarm50 seconds	
1350	hex	R		-	Alarm50 code	4B => 0x0104

MONITORING DATA						
Modbus register	Data				Description	Data values
	Type	Access	Range	Default		
2000	int	R	0-2	-	C5 Start/Stop current status	0-Stop, 1-Enabled but fans are stopped, 2-Running
2001	int	R	0-5	-	Current mode	0-Standby, 1-Comfort1, 2-Comfort2, 3-Economy1, 4-Economy2, 5-Special
2002-2003	int	R	-	-	Current supply flow	3500 => 3500 m3/h, 3.500 m3/s, 3500 l/s
2004-2005	int	R	-	-	Current exhaust flow	3500 => 3500 m3/h, 3.500 m3/s, 3500 l/s
2006	int	R	-500..1200	-	Current supply temp., C	250 => 25.0C
2007	int	R	-500..1200	-	Current extract temp., C	250 => 25.0C
2008	int	R	-500..1200	-	Current outdoor temp., C	250 => 25.0C
2009	int	R	-500..1200	-	Current exhaust temp., C	250 => 25.0C
2010	int	R	-500..1200	-	Current return water temp., C	250 => 25.0C
2011	int	R	0..1000	-	Supply air pressure	250 => 250 Pa
2012	int	R	0..1000	-	Extract air pressure	250 => 250 Pa
2013	int	R	0..4	-	Air quality sensor type	0-CO2, 1-VOCq, 2-VOCp, 3-RH, 4-TMP
2014	int	R	0..2000	-	Current air quality level	CO2: 0..2000ppm, VOC: 0..1000(0..100%), RH: 0..1000(0..100%), TMP: 0..500(0..50C)
2015	int	R	0..1000	-	Current supply air humidity	157 => 15.7%
2016	int	R	0..1000	-	Water heater level	
2017	int	R	0..1000	-	Water cooler level	
2018	int	R	0..1000	-	Humidity control level	
2019	int	R	0..1000	-	Heat exchanger level	
2020	int	R	0..1000	-	Recirculation level	
2021	int	R	0..1000	-	Supply fan level	
2022	int	R	0..1000	-	Exhaust fan level	
2023	int	R	0..1000	-	Outdoor air damper actuator level	

MONITORING DATA						
Modbus register	Data				Description	Data values
	Type	Access	Range	Default		
2024	int	R	0..1000	-	Exhaust air damper actuator level	
2025	int	R	0..1000	-	Electric heater level	
2026	int	R	-1000..1000	-	Heat pump level	
2027	int	R	-1000..1000	-	DX level	
2028	bin	R	0..1	-	OVR input	
2029	bin	R	0..1	-	Fire system input	
2030	bin	R	0..1	-	External stop input	
2031	bin	R	0..1	-	Control input	
2032	int	R	50..400	-	Current temp. setpoint, C	250 => 25.0C
2033	int	R	50..400	-	Current supply air temp. setpoint, C	250 => 25.0C
2034	bin	R	0..1	-	Water heater pump	
2035	bin	R	0..1	-	Water cooler pump	
2036-2037	int	R	-	-	Current supply flow setpoint	3500 => 3500 m <sup>3</sup> /h, 3.500 m <sup>3</sup> /s, 3500 l/s
2038-2039	int	R	-	-	Current extract flow setpoint	3500 => 3500 m <sup>3</sup> /h, 3.500 m <sup>3</sup> /s, 3500 l/s
2040	int	R	-500..1200	-	Current internal supply temp., C	250 => 25.0C
2041	int	R	-500..1200	-	Additional zone 1: current supply temp., C	250 => 25.0C
2042	int	R	-500..1200	-	Additional zone 1: current return water temp., C	250 => 25.0C
2043	int	R	-500..1200	-	Additional zone 2: current supply temp., C	250 => 25.0C
2044	int	R	-500..1200	-	Additional zone 2: current return water temp., C	250 => 25.0C
2045	int	R	0..1	-	Alarm DOUT	0-No alarms, 1-Active alarms
2046	int	R	0..400	-	Current supply air absolute humidity	250 => 25.0 g/m <sup>3</sup> or g/kg

MONITORING DATA						
Modbus register	Data				Description	Data values
	Type	Access	Range	Default		
2047	int	R	0..1	-	HP/CF Defrost active	
2200	bin	R		-	Counters/ efficiencies configuration	b8-Exhaust fan units(0-h, 1-kWh), b7-Supply fan units(0-h, 1-kWh), b6-Exhaust fan counter, b5-Heater counter, b4-Extract filter, b3-Outdoor filter, b2-Exhaust SFP, b1-Supply SFP, b0-HX efficiency (0-Unavailable, 1-Available)
2201	int	R	0..100, 255	-	Heat exchanger thermal efficiency, %	255 - Unavailable
2202	int	R	0..100, 255	-	Energy saving, %	255 - Unavailable
2203-2204	int	R		-	Heat exchanger recovery, W	2500 => 2.5kW (0xFFFF - Unavailable)
2205	int	R		-	Supply SFP	125 => 1.25
2206	int	R		-	Exhaust SFP	125 => 1.25
2207	int	R	0..100	-	Outdoor air filter impurity level, %	For AHU with filter pressure sensors
2208	int	R	0..100	-	Exhaust air filter impurity level, %	For AHU with filter pressure sensors
2209-2210	int	R	0..1'000'000	-	Air heater operation, hours	
2211-2212	int	R	0..50'000'000	-	Supply fan operation, hours or kWh	
2213-2214	int	R	0..50'000'000	-	Exhaust fan operation, hours or kWh	
2215	int	R	0..65535	-	Current supply fan power, W	
2216	int	R	0..65535	-	Current exhaust fan power, W	
2217	bin	R		-	Active functions	b5-OOD,b4-AQC,b3-SNC,b2-MTC, b1-OVR,b0-OCV
2218-2219	int	R	0..1'000'000	-	Air cooler operation, hours	
2220-2221	int	R	0..4'000'000	-	Heat exchanger operation, kWh	
2222-2223	int	R	0..4'000'000	-	Air heater operation, kWh	

MONITORING DATA ZONE 1						
Modbus register	Data				Description	Data values
	Type	Access	Range	Default		
2300	int	R	0..1000	-	Electric heater: level	
2301	int	R	0..1000	-	Electric heater: cooler level	
2302	int	R	-500..1200	-	Electric heater: air temperature	
2303	int	R	0..1000	-	Electric heater: air quality	
2304	int	R	0..1200	-	Electric heater: heater temperature	0..1200 when NTC sensor is selected, 0-1000 when TK70 sensor is selected
2305	bin	R	-	-	Electric heater: stages active	b3 – stage4, b2 – stage3, b1 – stage2, b0 – stage1
2306	bin	R	-	-	Electric heater: inputs	b2 – TK70, b1 – TK60, b0 – TK100
2307	bin	R	-	-	Electric heater: alarms	b2 – TK60 alarm, b1 – TK70 alarm, b0 – TK100 alarm
2310	int	R	0..1000	-	Water: heater level	
2311	int	R	0..1000	-	Water: cooler level	
2312	int	R	-500..1200	-	Water: air temperature	
2313	int	R	0..1000	-	Water: air quality	
2314	int	R	-300..1200	-	Water: return water temperature	
2315	bin	R	-	-	Water: outputs	b1 – cooling pump, b0 – heating pump
2316	bin	R	-	-	Water: inputs	b1 – combined coil is: 1-cooling, 0-heating, b0 – low water temperature,
2317	bin	R	-	-	Water: alarms	b0 – Low water temperature
2320	int	R	-1000..1000	-	DX level unit: level	> 0 – heating, < 0 – cooling, -32768 – forced stop
2321	int	R	0..1000	-	DX level unit: cooler level	
2322	int	R	-500..1200	-	DX level unit: air temperature	
2323	int	R	0..1000	-	DX level unit: air quality	
2325	bin	R	-	-	DX level unit: operating & stages active	b4 – reverse: 1-heating, 0-cooling, b3 – stage4, b2 – stage3, b1 – stage2, b0 – stage1
2326	bin	R	-	-	DX level unit: inputs	b0 – external error
2327	bin	R	-	-	DX level unit: alarms	b0 – external error alarm

MONITORING DATA ZONE 1						
Modbus register	Data				Description	Data values
	Type	Access	Range	Default		
2328	bin	R	-	-	DX stepping unit: external input	b0 – external input indication
2330	int	R	-1000..1000	-	DX modulated unit: level/ setpoint/error	Level or temperature setpoint (t → 0..10V) or temperature error signal (0..5..10V), depending on configuration
2331	int	R	0..1000	-	DX modulated unit: cooler level	
2332	int	R	-500..1200	-	DX modulated unit: air temperature	
2333	int	R	0..1000	-	DX modulated unit: air quality	
2335	bin	R	-	-	DX modulated unit: control outputs	b2 – heating, b1 – cooling, b0 – operation
2336	bin	R	-	-	DX modulated unit: inputs	b0 – external error
2337	bin	R	-	-	DX modulated unit: alarms	b0 – external error alarm
2338	bin	R	-	-	DX modulated unit: external input	b0 – external input indication

MONITORING DATA ZONE 2						
Modbus register	Data				Description	Data values
	Type	Access	Range	Default		
2400	int	R	0..1000	-	Electric heater: level	
2401	int	R	0..1000	-	Electric heater: cooler level	
2402	int	R	-500..1200	-	Electric heater: air temperature	
2403	int	R	0..1000	-	Electric heater: air quality	
2404	int	R	0..1200	-	Electric heater: heater temperature	0..1200 when NTC sensor is selected, 0-1000 when TK70 sensor is selected
2405	bin	R	-	-	Electric heater: stages active	b3 – stage4, b2 – stage3, b1 – stage2, b0 – stage1
2406	bin	R	-	-	Electric heater: inputs	b2 – TK70, b1 – TK60, b0 – TK100
2407	bin	R	-	-	Electric heater: alarms	b2 – TK60 alarm, b1 – TK70 alarm, b0 – TK100 alarm
2410	int	R	0..1000	-	Water: heater level	
2411	int	R	0..1000	-	Water: cooler level	

MONITORING DATA ZONE 2						
Modbus register	Data				Description	Data values
	Type	Access	Range	Default		
2412	int	R	-500..1200	-	Water: air temperature	
2413	int	R	0..1000	-	Water: air quality	
2414	int	R	-300..1200	-	Water: return water temperature	
2415	bin	R	-	-	Water: outputs	b1 – cooling pump, b0 – heating pump
2416	bin	R	-	-	Water: inputs	b1 – combined coil is: 1-cooling, 0-heating, b0 – low water temperature,
2417	bin	R	-	-	Water: alarms	b0 – Low water temperature
2420	int	R	-1000..1000	-	DX level unit: level	> 0 – heating, < 0 – cooling, -32768 – forced stop
2421	int	R	0..1000	-	DX level unit: cooler level	
2422	int	R	-500..1200	-	DX level unit: air temperature	
2423	int	R	0..1000	-	DX level unit: air quality	
2425	bin	R	-	-	DX level unit: operating & stages active	b4 – reverse: 1-heating, 0-cooling, b3 – stage4, b2 – stage3, b1 – stage2, b0 – stage1
2426	bin	R	-	-	DX level unit: inputs	b0 – external error
2427	bin	R	-	-	DX level unit: alarms	b0 – external error alarm
2428	bin	R	-	-	DX stepping unit: external input	b0 – external input indication
2430	int	R	-1000..1000	-	DX modulated unit: level/ setpoint/error	Level or temperature setpoint (t → 0..10V) or temperature error signal (0..5..10V), depending on configuration
2431	int	R	0..1000	-	DX modulated unit: cooler level	
2432	int	R	-500..1200	-	DX modulated unit: air temperature	
2433	int	R	0..1000	-	DX modulated unit: air quality	
2435	bin	R	-	-	DX modulated unit: control outputs	b2 – heating, b1 – cooling, b0 – operation
2436	bin	R	-	-	DX modulated unit: inputs	b0 – external error
2437	bin	R	-	-	DX modulated unit: alarms	b0 – external error alarm

MONITORING DATA ZONE 2						
Modbus register	Data				Description	Data values
	Type	Access	Range	Default		
2438	bin	R	-	-	DX modulated unit: external input	b0 – external input indication

SERVICE						
Modbus register	Data				Description	Data values
	Type	Access	Range	Default		
900	bin	R/W		0	Modes reset to default	b4-Special, b3-Economy2, b2-Economy1, b1-Comfort2, b0-Comfort1
901	bin	R/W		0	Functions reset to default	b9-ZN2, b8-ZN1, b7-HUM, b6-REC, b5-OOD, b4-SNC, b3-OVR, b2-MTC, b1-OCV, b0-AQC
902	bin	R/W		0	Settings reset to default	b3-485_Config, b2-IP+Mask, b1-Flow_mode, b0-Temp_mode
2852	bin	R	0..1	-	Digital input: Outdoor filter	For AHU without filter pressure sensors. 0-Clean, 1-Dirty
2853	bin	R	0..1	-	Digital input: Extract filter	For AHU without filter pressure sensors. 0-Clean, 1-Dirty
18000	int	R/W	0	-	User password reset	Write 0x99C5 to reset
18001	int	R/W	0	-	User settings reset	Write 0x99C5 to reset
18002	int	R/W	0	-	Clean air filters calibration	Write 0x99C5 to start calibration
18003	int	R/W	0	-	Counters reset	Write 0x??C5 to reset, ?? => b2-Exhaust fan, b1-Supply fan, b0-Air heater (1 – Reset). 0X01C5 => Reset air heater counter only, 0x07C5 => Reset both fans and air heater counters
18004	int	R	0..9999	-	Controller firmware version	
18005	int	R/W	0..1000	0	Service time counter	0..100.0%, Write 0x99C5 to reset

### Alarm codes (registers 1000-1350)

Code			Text	Alarm text
Hex	Dec			
1	1	1B		Low supply air flow
2	2	2B		Low extract air flow
3	3	3B		VAV calibration fail
4	4	4B		Change outdoor air filter
5	5	5B		Change extract air filter
6	6	6B		
7	7	7B		
8	8	8B		
9	9	9B		
A	10	10B		
B	11	11B		Electric heater off

Code		Text	Alarm text
Hex	Dec		
C	12	12B	High pressure on compressor
D	13	13B	Low pressure on compressor
E	14	14B	Service time
F	15	15B	Evaporator icing
10	16	16B	Heat pump malfunction
11	17	17B	
12	18	18B	
13	19	19B	Compressor off
14	20	20B	
15	21	21B	High pressure on compressor
16	22	22B	Low pressure on compressor
17	23	23B	Heat pump malfunction
18	24	24B	
19	25	25B	
1A	26	26B	
1B	27	27B	Heat pump malfunction
1C	28	28B	
1D	29	29B	
1E	30	30B	
1F	31	31B	
20	32	32B	
21	33	33B	
22	34	34B	
23	35	35B	
24	36	36B	
25	37	37B	
26	38	38B	
27	39	39B	
28	40	40B	
29	41	41B	
2A	42	42B	
2B	43	43B	
2C	44	44B	Heat pump malfunction or Communication error

Code		Text	Alarm text	
Hex	Dec			
2D	45	45B	Heat pump malfunction	
2E	46	46B		
2F	47	47B		
30	48	48B		
31	49	49B		
32	50	50B		
33	51	51B		
34	52	52B		
35	53	53B		
36	54	54B		
37	55	55B		
38	56	56B		
39	57	57B		
3A	58	58B		
3B	59	59B		Heat pump malfunction or Communication error
3C	60	60B		Heat pump malfunction
3D	61	61B		
3E	62	62B		
3F	63	63B		
40	64	64B		
41	65	65B		
42	66	66B		
43	67	67B		
44	68	68B		
45	69	69B		
46	70	70B		
47	71	71B		
48	72	72B		
49	73	73B		
4A	74	74B		
4B	75	75B		
4C	76	76B		
4D	77	77B		
4E	78	78B	Heat pump malfunction	
4F	79	79B		
50	80	80B		
51	81	81B		
52	82	82B		
53	83	83B		Heat pump malfunction or Communication error

Code		Text	Alarm text	
Hex	Dec			
54	84	84B	Heat pump malfunction	
55	85	85B		
56	86	86B		
57	87	87B		
58	88	88B		
59	89	89B		
5A	90	90B		
5B	91	91B		
5C	92	92B		
5D	93	93B		
5E	94	94B		
5F	95	95B		Low heat exchanger efficiency
60	96	96B		Communication error
61	97	97B		
62	98	98B		
63	99	99B	Communication error	
64	100	100B	Heat pump malfunction	
65	101	101B		
66	102	102B		
67	103	103B		
68	104	104B		
69	105	105B		
6A	106	106B		
6B	107	107B		
6C	108	108B		
6D	109	109B		
6E	110	110B		
6F	111	111B		
70	112	112B	Water pump/coil alarm	
71	113	113B	CF or HP exchanger not calibrated	
72	114	114B	CF or HP exchanger not calibrated	
73	115	115B	High pressure on compressor	
74	116	116B	Low pressure on compressor	
75	117	117B	Heat pump malfunction	
76	118	118B		
77	119	119B		
78	120	120B		
79	121	121B		
7A	122	122B	Unknown alarm	
7E	126	126B		
7F	127	127B	Service mode	

Code		Text	Alarm text
Hex	Dec		
80	128	1A	Supply air temp. Sensor failure
81	129	2A	
82	130	3A	Extract air temp. Sensor failure
83	131	4A	
84	132	5A	Outdoor air temp. Sensor failure
85	133	6A	
86	134	7A	Exhaust air temp. Sensor failure
87	135	8A	
88	136	9A	Water temp. sensor failure
89	137	10A	
8A	138	11A	Return water temp. low
8B	139	12A	Internal fire alarm
8C	140	13A	External fire alarm
8D	141	14A	External stop
8E	142	15A	Heat exchanger failure
8F	143	16A	Heat exchanger icing
90	144	17A	Low supply air temperature
91	145	18A	High supply air temperature
92	146	19A	Low supply air flow
93	147	20A	Low extract air flow
94	148	21A	Electric heater overheat
95	149	22A	
96	150	23A	Evaporator air temp. Sensor failure
97	151	24A	
98	152	25A	Evaporator coil temp. Sensor failure
99	153	26A	
9A	154	27A	Compressor failure
9B	155	28A	
9C	156	29A	Supply air temp. Sensor failure
9D	157	30A	
9E	158	31A	Water temp. sensor failure
9F	159	32A	
A0	160	33A	Return water temp. Low
A1	161	34A	
A2	162	35A	Supply air temp. Sensor failure
A3	163	36A	
A4	164	37A	Water temp. sensor failure
A5	165	38A	
A6	166	39A	Return water temp. Low
A7	167	40A	
A8	168	41A	Supply air temp. Sensor failure
A9	169	42A	

Code		Text	Alarm text
Hex	Dec		
AA	170	43A	External stop
AB	171	44A	
AC	172	45A	Water pump/coil alarm
AD	173	46A	CF exchanger not calibrated
D2	210	83A	Controller failure
D3	211	84A	Communication error
D4	212	85A	
D5	213	86A	
D6	214	87A	
D7	215	88A	
D8	216	89A	
D9	217	90A	
DA	218	91A	
DB	219	92A	Controller failure
DC	220	93A	
DD	221	94A	
DE	222	95A	
DF	223	96A	
E0	224	97A	
E1	225	98A	
E2	226	99A	
E3	227	100A	Supply fan drive overload
E4	228	101A	Supply fan motor failure
E5	229	102A	Supply fan motor overload
E6	230	103A	
E7	231	104A	Exhaust fan drive failure
E8	232	105A	Exhaust fan drive overload
E9	233	106A	Exhaust fan motor failure
EA	234	107A	Exhaust fan motor overload
EB	235	108A	
EC	236	109A	Rotor drive failure
ED	237	110A	Rotor drive overload
EE	238	111A	Rotor motor failure
EF	239	112A	Rotor motor overload
F0	240	113A	

Code		Text	Alarm text	
Hex	Dec			
F1	241	114A	Communication error	
F2	242	115A		
F3	243	116A		
F4	244	117A		
F5	245	118A		
F6	246	119A		
F7	247	120A		
F8	248	121A		
F9	249	122A		
FA	250	123A		
FB	251	124A		
FC	252	125A		Controller failure
FD	253	126A		
FE	254	127A		

## SERVICE AND SUPPORT

### LITHUANIA

#### UAB KOMFOVENT

Phone: +370 5 200 8000  
service@komfovent.com  
www.komfovent.com

### FINLAND

#### Komfovent Oy

Muuntotie 1 C1  
FI-01 510 Vantaa, Finland  
Phone: +358 20 730 6190  
toimisto@komfovent.com  
www.komfovent.com

### GERMANY

#### Komfovent GmbH

Konrad-Zuse-Str. 2a,  
42551 Velbert, Deutschland  
Phone: +49 0 2051 6051180  
info@komfovent.de  
www.komfovent.de

### LATVIA

#### SIA Komfovent

Bukaišu iela 1, LV-1004 Riga, Latvia  
Phone: +371 24 66 4433  
info.lv@komfovent.com  
www.komfovent.com

### SWEDEN

#### Komfovent AB

Ögärdesvägen 12A  
433 30 Partille, Sverige  
Phone: +46 31 487 752  
info\_se@komfovent.com  
www.komfovent.se

### UNITED KINGDOM

#### Komfovent Ltd

Unit C1 The Waterfront  
Newburn Riverside  
Newcastle upon Tyne NE15 8NZ, UK  
Phone: +447983 299 165  
steve.mulholland@komfovent.com  
www.komfovent.com

## PARTNERS

AT	J. PICHLER Gesellschaft m. b. H.	www.pichlerluft.at
BE	Ventilair group ACB Airconditioning	www.ventilairgroup.com www.acbairco.be
CZ	REKUVENT s.r.o.	www.rekuvent.cz
CH	WESCO AG SUDCLIMATAIR SA CLIMAIR GmbH	www.wesco.ch www.sudclimatair.ch www.climair.ch
DK	Øland A/S	www.oeland.dk
EE	BVT Partners	www.bvtpartners.ee
FR	ATIB	www.atib.fr
HR	Microclima	www.microclima.hr
HU	AIRVENT Légtechnikai Zrt. Gevent Magyarorszáig Kft. Merkapt	www.airvent.hu www.gevent.hu www.merkapt.hu
IE	Lindab	www.lindab.ie
IR	Fantech Ventilation Ltd	www.fantech.ie
IS	Blikk & Tækniþjónustan ehf Hitataekni ehf	www.bogt.is www.hitataekni.is
IT	ICARIA	www.icaria.srl
NL	Ventilair group DECIPOL-Vortvent CLIMA DIRECT BV	www.ventilairgroup.com www.vortvent.nl www.climadirect.com
NO	Ventilution AS Ventistål AS Thermo Control AS	www.ventilution.no www.ventistal.no www.thermocontrol.no
PL	Ventia Sp. z o.o.	www.ventia.pl
SE	Nordisk Ventilator AB	www.nordiskventilator.se
SI	Agregat d.o.o	www.agregat.si
SK	TZB produkt, s.r.o.	www.tzbprodukt.sk
UA	TD VECON LLC	www.vecon.ua